

MNMS18A 砂辊碾米机

EMERY ROLL RICE WHITENING MACHINE



MNMS18A 砂辊碾米机

MNMS18A砂辊米机主要用于大、中型碾米企业的开糙和碾白，采用目前国际上先进的负压碾米技术，使碾白过程的米温降低，含糠少，增碎更小。

特点

- 设计新颖、造型美观；
- 机械性能稳定，结构紧凑，装拆方便；
- 独特的米刀调节装置，操作更方便；
- 强负压碾米，精度高、排糠快、增碎少。

MNMS18A emery-roll whitener applies mainly to mill and whiten for large-sized and mediumsized rice processing plants. due to adopt current advanced milling technique of negative pressure in the world, the machine makes rice temperature low, bran few and brokens fewer in whitening.

Feature

- Novel design, good in appearance.
- Mechanical properties and stability, compact structure, convenient assembly and disassembly.
- A unique adjustment device for blade, easy to operate.
- Strong negative pressure rice milling, high accuracy, bright surface, little broken rice increase.

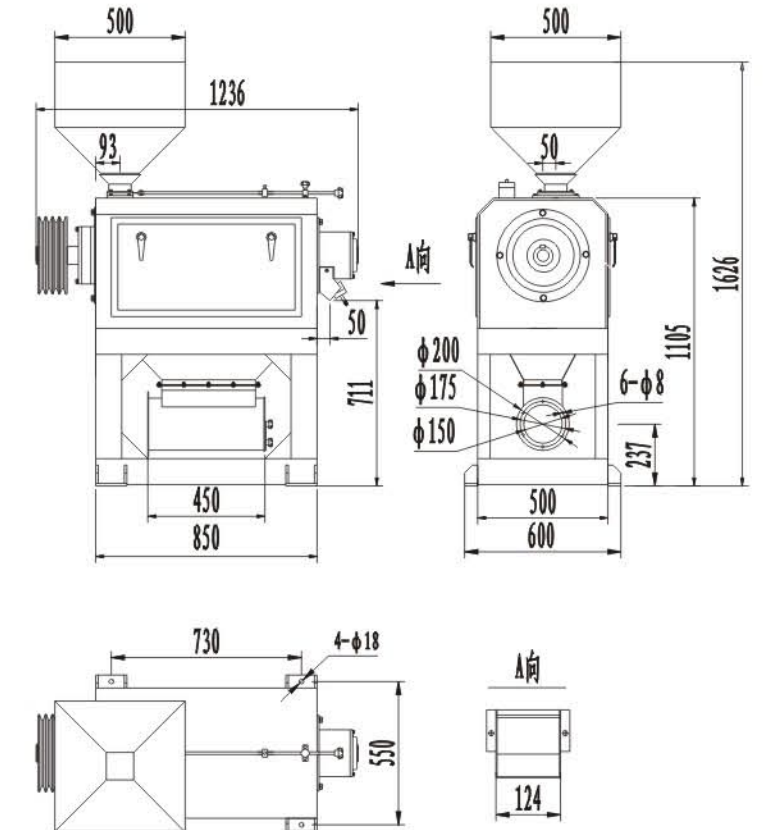

(外形尺寸与地脚安装图)

主要技术参数

型号 Type	MNMS18A
处理量 Output(t/h)	2-2.5
动力配备 Power(kw)	18.5-22
主轴转速 Rotary speed(rpm)	955-1550
负压 Negative pressure(mmH ₂ O)	150-200
风量 Air volume(m ³ /min)	20-25
机重 Weight(kg)	350

通过ISO9001国际标准质量体系认证 产品技术参数如有变更恕不另行通知 If technologic data has been changed without further information

E-mail: yongxiangmiji@sohu.com http://www.hbyxjlj.com

地址: 湖北省安陆市府河大道2号

ADD: 2 FUHE AVE. ANLU CITY, HUBEI, CHINA

电话(TEL): 0712-5254443 5254445 5258762 传真(FAX): 0712-5254443 邮编(POSTCODE): 432600

湖北永祥粮食机械股份有限公司

HUBEI YONGXIANG FOOD PROCESSING MACHINE CO.,LTD.